



# E - Tech

## CAR TRANSPORTING MADE EASY



PULL OUT / PUSH IN EASY TO OPERATE RAMPS WITH PRG SUPER GRIP



BRADLEY AUTO LOCK CAST BODY AND CAST HEAD COUPLING



WELL PROTECTED LIGHTING SYSTEM WITH "SUPERSEAL" WIRING CONNECTIONS

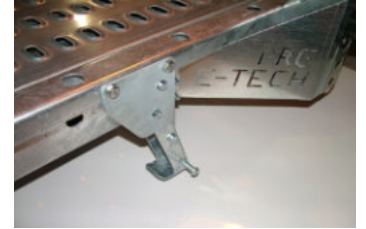

COMPACT FOLD DOWN REAR SUPPORT STANDS



**Leroni Trailers Ltd**  
Dunshauglin, Co. Meath, Phone 046-9052101 or 086-8073379  
email:- [info@leroni.ie](mailto:info@leroni.ie)  
WWW. LERONITRAILERS.IE



# E – Tech

## CAR TRANSPORTING MADE EASY

BY LISTENING TO OUR CUSTOMERS REQUIREMENTS PRG TRAILERS INTRODUCE A BRAND NEW DESIGN TRAILER ACHIEVED BY BOTH NEW IDEAS AND PUTTING TOGETHER A NUMBER OF THE BEST FEATURES FROM OTHER MODELS IN OUR EXISTING RANGE.

THE E –TECH 77 GIVES AN EXTRA WIDE BED FOR TODAY'S MODERN WIDE AND LOW CARS. SUPER-GRIP TRANSPORTER DECKING GIVES CLASS LEADING MULTIPLE TIEING DOWN POSITIONS AND THE ADDED SAFETY OF VEHICLE BEING CARRIED TOTALLY SECURE ON THE EXTRA GRIP GIVEN BY THE PUNCHED TRANSPORTER DECKING. THE PULL OUT, PUSH IN RAMP SYSTEM MAKES LOADING AND UNLOADING THE QUICKEST AND EASIEST OF OPERATIONS. IDEAL FOR BOTH COMMERCIAL USE AND THE PRIVATE INDIVIDUAL.

### E-TECH 77 OPTIONAL EXTRAS

CENTRE DECK  
TYRE RACK  
JERRY CAN BOX  
ELECTRIC WINCH  
ADJUSTABLE WHEEL CHOCKS  
LED LIGHTING PACKAGE

	E-TECH 68	E-TECH 77	E-TECH 77	E-TECH 77
BED SIZE	11' X 5'8" (3.35M X 1.73M)	12' X 6'5" (3.66M X 1.95M)	14' X 6' 5" (4.26M X 1.95M)	15'3" X6'5" (4.65M X 1.95M)
BED LENGTH (A)	11' (3.35M)	12' (3.66M)	14' (4.26M)	15'3" (4.65M)
BED WIDTH (B)	5' 8" (1.73M)	6'5" (1.95M)	6'5" (1.95M)	6'5" (1.95M)
OVERALL LENGTH (C)	14' 10" (4.52M)	16' 2" (4.93M)	18'2" (5.53M)	19'5" (5.92M)
OVERALL WIDTH (D)	6' 10" (2.08M)	7'6" (2.3M)	7'6" (2.3M)	7'6" (2.3M)
HEIGHT (E) Floor to bed	16.75" (0.425M)	16.75" (0.425M)	16.75" (0.425M)	16.75" (0.425M)
HEIGHT (F) Floor to highest point	24" (0.60M)	24" (0.60M)	24" (0.60M)	24" (0.60M)
GROSS WEIGHT	2000KG	2000KG	2000KG/2600KG	2600KG
LOAD CAPACITY	1480KG	1430 KG	1375KG/1975KG	1910KG

	E-TECH 81	E-TECH 81
BED SIZE	14'X 6 '9" (4.26M X 2.05M)	15'3" X 6'9" (4.65M X 2.05M)
BED LENGTH (A)	14' (4.26M)	15'3" (4.65M)
BED WIDTH (B)	6'9" (2.05M)	6'9" (2.05M)
OVERALL LENGTH (C)	18'2" (5.53M)	19'5" (5.92M)
OVERALL WIDTH (D)	7' 10" (2.4M)	7' 10" (2.4M)
HEIGHT (E) Floor to bed	16.75" (0.425M)	16.75" (0.425M)
HEIGHT (F) Floor to highest point	24" (0.60M)	24" (0.60M)
GROSS WEIGHT	2000KG/2600KG	2600KG
LOAD CAPACITY	1355KG/1955KG	1890KG



FULL EU TYPE  
APPROVAL

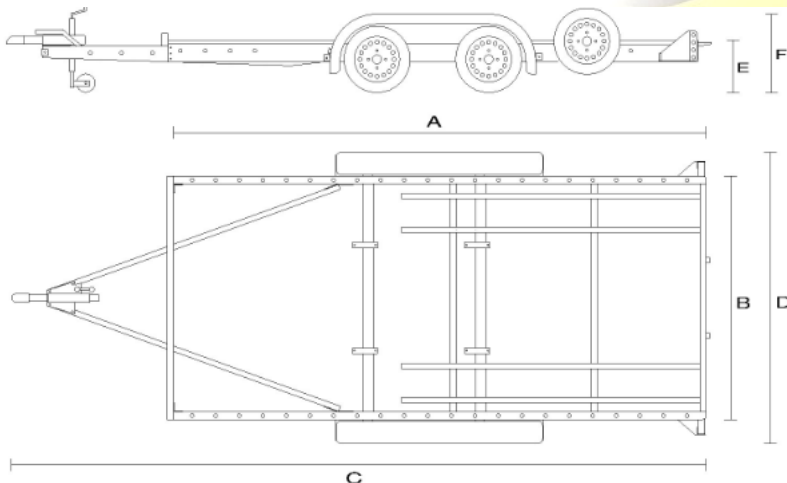

### FEATURES

- \* FULLY GALVANISED CHASSIS.
- \* PUNCH SLOTTED TRANSPORTER DECKING.
- \* 2.5M PULL OUT / PUSH IN RAMPS.
- \* AUTO REVERSE BRAKING TO ALL WHEELS.
- \* ENCLOSED MUDGUARDS.
- \* BRADLEY CAST BODY, CAST HEAD HITCH.
- \* WINCH.
- \* SPARE WHEEL & TYRE.
- \* TOW HITCH LOCK.
- \* WELL PROTECTED LIGHTING SYSTEM.
- \* KICK DOWN REAR SUPPORT STANDS.

**PRG TRAILERS**